

# SPIDER 18.90

SELF-PROPELLED AERIAL WORK PLATFORMS

## New **PRO** VERSION

- Big working envelope
- Reduced vibration and noise
- Available with Diesel KUBOTA engine.
- Electric version & battery Lithium Tech. available on demand.

## EASY MAINTENANCE

- Easy access for maintenance
- Easy to use with smooth and precise controls.



**PL** **TFORM**  
B A S K E T

# SERIE SPIDER 18.90

## BEST PERFORMANCES

### 1. Greater Versatility with Fly Jib

- The FLY JIB has 2 big advantages, it gives a greater outreach and allows the basket to be smoothly operated.
- The fly jib with 160° movements offers a greater versatility and flexibility, improving the working area and making easier to reach points otherwise impossible to be reached.



### 2. Attention To Detail

- Compact design & highest quality components – reliable and robust.
- Full protection of the electric and hydraulic components by means of metal covers, including leg rams.
- Air, Water & 230/110 Vac outlets into the basket as standard.
- Cranked outrigger design for increased ground clearance.



### 3. Enjoy the experience of easy controls

- Proportional, smooth and precise hydraulic controls.
- On demand the wireless remote that includes a spare battery and charger.
- The system is supplied with a spare cable to let the operator drive the machine in case of dead radio battery or in areas on which the radio frequencies are not allowed



### 4. Automatic & Proportional side outreach control

- The safety system automatically reduces the outreach by monitoring the weight in the basket.
- It allows the machine to operate up to the maximum height with 200 kg lifting capacity.



### 5. Two Speed tracking

- It can be equipped with double proportional driving speed up to 2,5 Km/h in order to guarantee an easy and fast drive with combustion engine.
- The fast speed selection enables a good drive speed even when powered by batteries or 110Vac.



### 6. Quick detach and interchangeable cage

- Aluminium basket is easy to remove.
- It's really interesting to see that even with the cage rotation, the basket can be easily detached thanks to the aid of two wheels.
- All detachable baskets are connected to the support with no devices protruding underneath the cage.



### 7. Variable track width with no hydraulic devices.

- An exclusive undercarriage developed by Platform Basket makes it possible to extend or retract the tracks enabling better platform stability when driven.
- The narrow tracks position makes the machine 0,78m wide and less than 2,00m height.
- The wide tracks position makes the model easy to be driven off-road or on slopes.



### 8. Electronic Level Indicator

- A high precision level gauge fitted to the spider chassis allows the platform movements only when it is leveled within 1,5 deg.
- Particularly useful for the rental industry.



## OVERALL DIMENSIONS

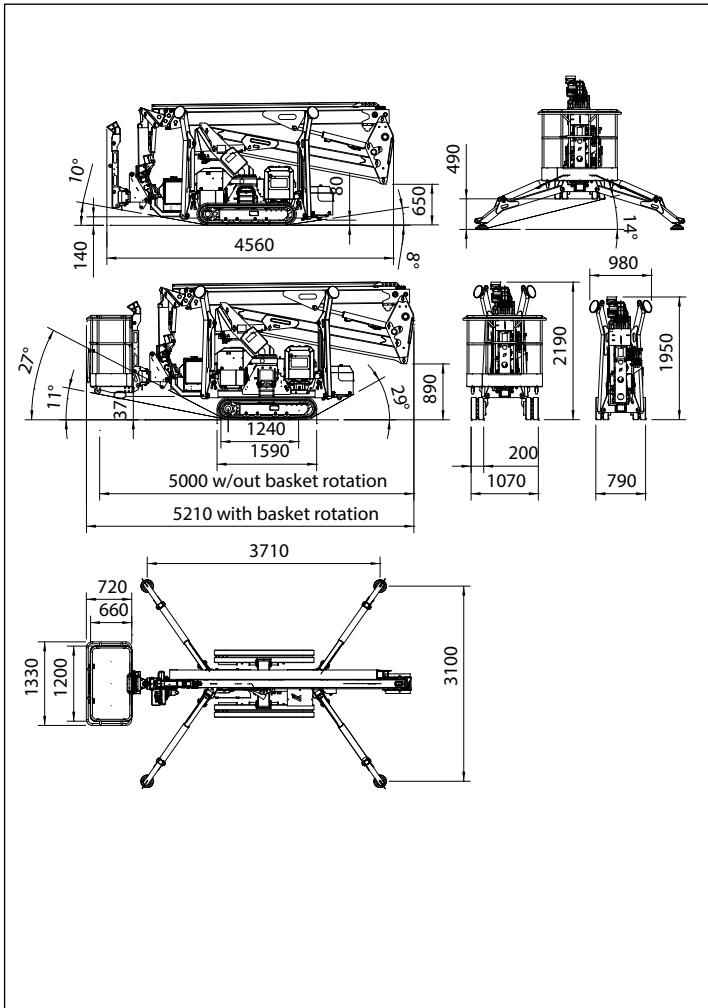

## WORKING ENVELOPE

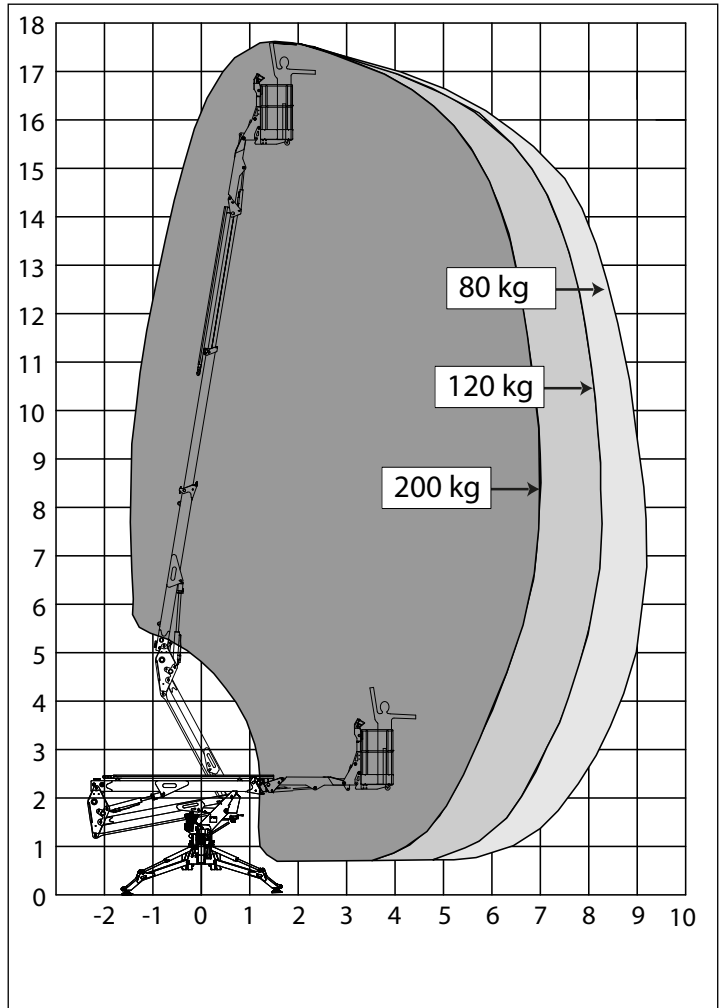

## OPERATIONS



# SERIE SPIDER 18.90

TECHNICAL DATA		VERSION	
		STD	E
Max working height	m	17,60	
Max height basket floor	m	15,60	
Max side outreach	m	9,20	
Rotation angle	°	360	
Basket size (standard version)	m	1,30 x 0,70	
Basket rotation angle	°	70+70	
Max basket capacity (2 men)	Kg	200	
Length in stowed position (with detached basket)	m	5,00	
	m	4,36	
Min width in stowed position	mm	780	
Min height in stowed position	mm	1950	
Stabilization foot-print	m	3,00 x 3,63	
Max gradeability	Deg / %	16° (29%)	
Max side gradeability	Deg / %	17° (31%)	
Max drive speed (slow/fast)	Km/h	1,5 / 2,5	0,8 / 1,5
WEIGHTS		STD	E
Weight in working config.*	Kg	2.350*	2.500*
Ground pressure stowed machine (narrow tracking)	KN/m²	3,69	
Ground pressure when on stabilizers.	KN/m²	2,25	
Max point load per outrigger plate	KN	17,50	
POWER		STD	E
iGX Honda engine (gasoline)	hp/rpm¹	13/3600	--
Z482 Kubota engine (diesel)	hp/rpm¹	13/3200	--
Electric motor 230Vac/50Hz 110Vac/60Hz	KW / hp	2,20 / 3	2,20 / 3
	KW / hp	1,50 / 2	1,50 / 2
Electric motor 24Vdc	KW / hp	-	3,5 / 4,8
Battery capacity 24Vdc lead/acid 24Vdc lithium-ion	Ah	-	210
	Ah	-	300
Battery charger - lead/ battery Battery charger - Lithium-ion	Ah	-	45
	Ah	-	100 / 45

\* May differs due to the configuration.

STANDARD EQUIPMENTS		VERSION	
		STD	E
Double articulated boom with telescopic upper boom and flying jib		•	
Honda iGX390 combustion engine (diesel on demand)		•	--
Smooth and proportional drive speed		•	
Live hydraulic controls into the basket		•	
Stabilization monitored by an electronic planarity sensor (max 1,5deg)		•	
All components are well protected against objects fall.		•	
Light allu basket and easily detachable.		•	
Air-water and 230/110Vac outlets in the basket		•	
Hydraulic basket rotation 80+80 deg		on demand	•
Extendable undercarriage with diagonal set-up.		•	
Deep-cycle batteries 24Vdc, electric power-pack for indoor use		--	•
Battery charger 24Vdc with power selector.		--	•
Single Phase electric pump 230/110Vac for indoor use.		•	
Built-in fault messages diagnostic		•	
EXTRAS - ON DEMAND		STD	E
Non marking rubber tracks particularly suitable for delicate floors.		•	STD
Double drive speed system with slow/fast selector control		•	STD
Two cylinders liquid cooled diesel Kubota Z482 engine with automatic speed governor.		•	--
Radio remote control unit for drive and stabilization including automatic set-up. (supplied with spare battery, on-board battery charger and emergency cable)		•	
Electric power pack for emergency descent (12Vdc).		•	--
Quick and easy detachable single man basket.		•	
Oversized foot plates for soft ground.(diam.330mm)		•	
Oversized square 40x40cm nylon plates supplied with on-board housing frame.		•	
Arctic lubricants for cold climate		•	
Biodegradable hydraulic oil		•	
Basket working light		•	
Lithium-ion battery pack for longer working cycle		--	•
APPROVALS			
EUROPE: EN280 - CANADA: CS-B354 - AUSTRALIA: AS1418			

**STD**

- Combustion engine
- Electric motor-pump single phase 230/110 Vac

**E - ELECTRIC**

- Electric motor-pump single phase 230/110 Vac
- Electric pump 24Vdc with deep cycle battery



**PLATFORM BASKET**

Via Montessori, 1 - 42028 Poviglio - RE - Italy  
Tel. +39 0522 967666 - Fax +39 0522 967667  
info@platformbasket.com

