

SERIE

SPIDER 33.15

SELF-PROPELLED AERIAL WORK PLATFORMS

The most reliable, compact and flexible in use.

- Bi-energy Diesel + Litium Ion batteries available on demand
- Bi-energy Diesel + Electric power pack 380Vac/15Hp

SIMPLIFIED MAINTENANCE

- Easy access to any maintenance compartment.
- On-board diagnostics
- Tele assistance on demand



PLA/TFORM

B A S K E T

BEST PERFORMANCES

1. Double telescopic articulated boom

- 17m 'Up & Over' working.
- Easy lift of the basket keeping a constant distance from the wall
- Capability to be operated 6m below ground level.



2. Enjoy the experience of easy controls

- Proportional, smooth and precise movements are proportional
- Automatic & proportional side outreach that allows the users to enjoy the sensation of stability, reliability and full control of the spider
- Radio remote control, with a selector fast/slow for the drive, automatic recovery bottom, standard automatic stabilization and self-diagnostic. The system is supplied with a spare cable



3. Attention to the details

- Compact design & highest quality components – reliable and robust
- Global protection of the electric and hydraulic components by means of metal covers, including leg rams.
- No pipes and hoses are left outside without protection.
- Air & Water & 220 or 110 Vac outlets into the basket as main standards.
- Cranked outrigger design for increased ground clearance



4. Multi-width stabilizers setting.

- Triple stabilization set-up and automatic monitoring device.
- 360 deg of rotation angle available with 230kg into the basket.
- Possibility to self-loading and unloading of the machine on a flat-bed truck body.



5. Automatic & Proportional Outreach side Control

- The safety system automatically reduce the outreach by monitoring always the weight into the basket and the residual load on each foot by means of load cells.
- The automatic outreach allows to operate up to the maximum height with 230 kg lifting capacity.



6. Remote diagnostics and fleet management

- The remote diagnostics helps offering a range of unique benefits, including immediate communication of actionable information so you can make decisions in real-time.
- Proactive diagnostic and repair planning assistance with detailed analysis of critical fault codes, and update of the software.
- In addition the GPS locator allows you to know exactly where the spider is.



7. Quick detach and interchangeable cage

- Aluminium basket easy to remove.
- All detachable basket are connected to the support with no devices protruding underneath the cage.
- Available in 3 different sizes according to your needs (1,50- 1,80 - 2,20m wide)



8. Hydraulic track widening system

- When tracks are fully retracted and the booms fully stowed, the height is 1,99m only instead of 2,25m and the width 1,39m with basket fitted to the tip of the boom instead of 1,69 in wide position.
- Excellent versatility on narrow doorway passages.
- Two speed tracking up to 2,00 Km/h.



OVERALL DIMENSIONS

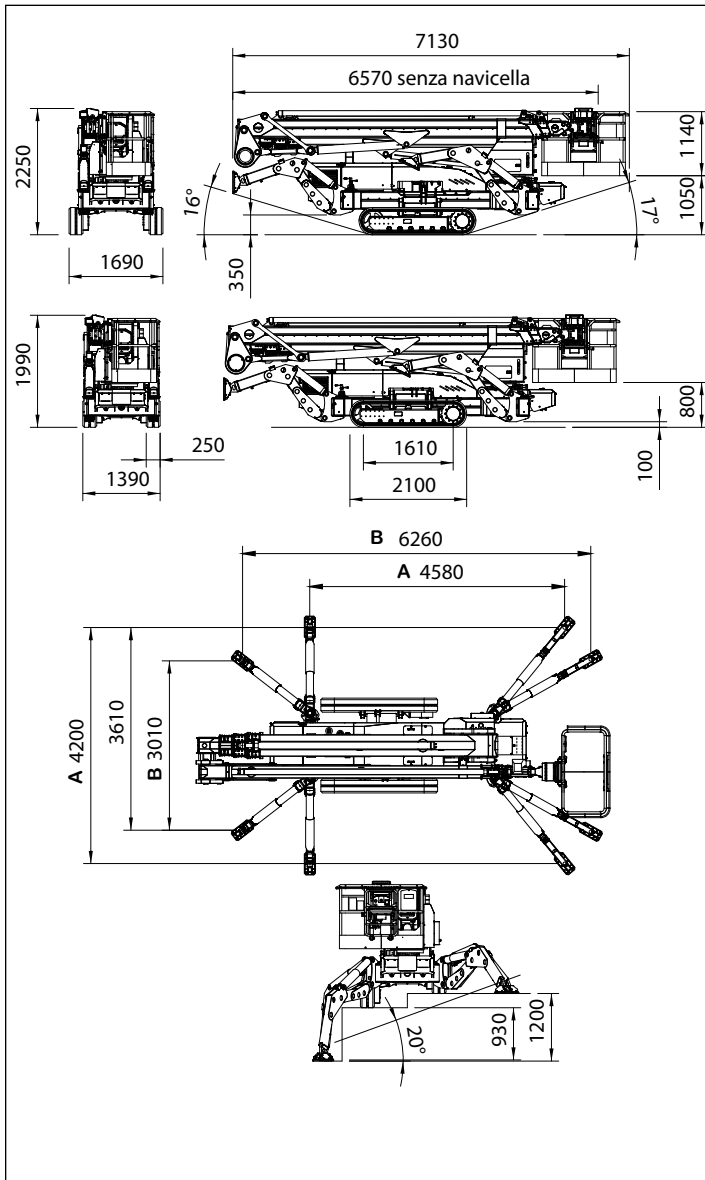

WORKING ENVELOPE

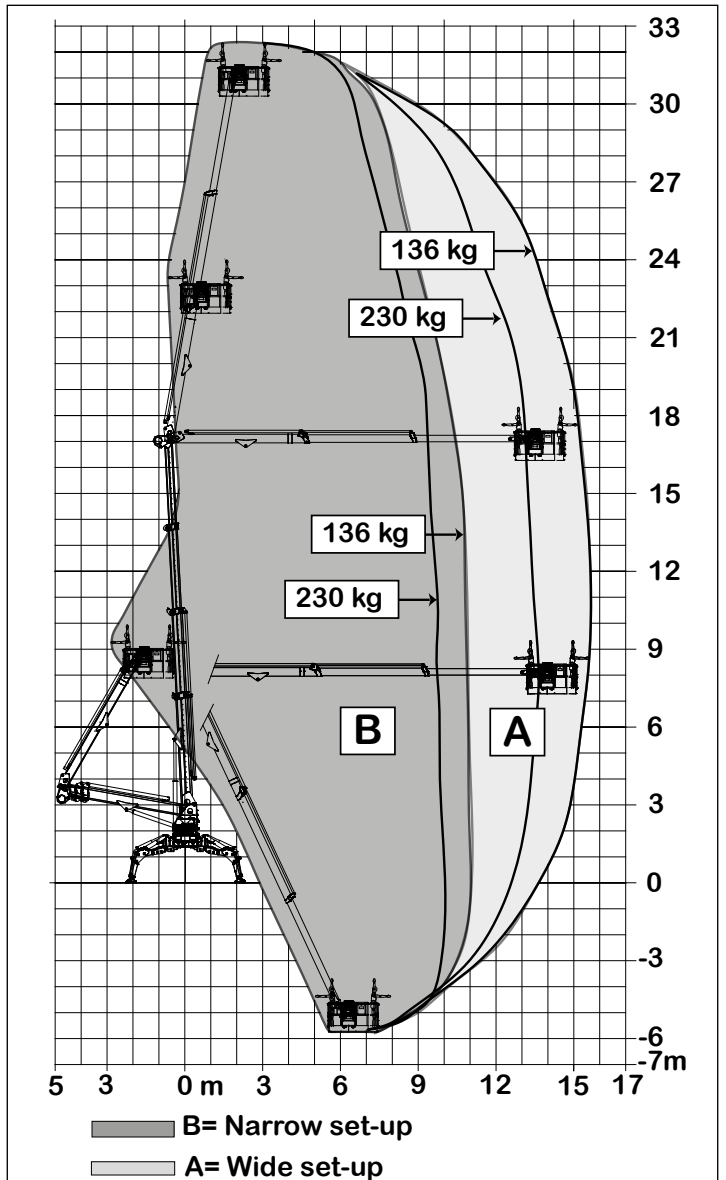

OPERATIONS



SERIE SPIDER 33.15

TECHNICAL DATA		VERSION		
		STD	E	ED
Max working height	m	32,40		
Max height basket floor	m	30,40		
Max side outreach	m	15,60		
Rotation angle	°	400		
Basket size (standard version)	m	1,63 x 0,87		
Basket rotation angle	°	90+90		
Max basket capacity (2 men)	Kg	230		
Length in stowed position (with detached basket)	m	7,13		
	m	6,57		
Min width in stowed position	m	1,39		
Min height in stowed position	m	1,99		
Stabilization foot-print	m	wide 4,21 x 4,58		
	m	narrow 3,07 x 6,26		
Max gradeability	deg/%	16° (29%)		
Max side gradeability	deg/%	17° (31%)		
Max speed	Km/h	2,0	1,2	2,0
WEIGHTS		STD	E	ED
Weight in working config.*	Kg	6500*	6800*	6800*
Ground pressure stowed machine (narrow tracking)	KN/m ²	6,75	7,03	7,03
Ground pressure when on stabilizers.	KN/m ²	3,48	3,48	3,61
Max point load per outrigger plate	KN	37,6	37,6	39,0
POWER		STD	E	ED
Engine D902 Kubota diesel	hp/rpm	22/3600	-	22/3600
Electric motor 380Vac	hp/Volt	15/380	15/380	-
Electric motor 24Vdc	hp/Volt	-	7,4/24	7,4/24
Battery capacity 24Vdc lead/acid	Ah	-	2x210	2x210
	Ah	-	400	400
Battery charger - lead battery	Ah	-	45	45
Battery charger - Lithium-ion	Ah	-	100/50	100/50

* Some weights may differ due to the chosen optionals.



STD

- Combustion diesel engine
- 15CV electric motor with power pack



E - ELECTRIC

- Electric motor 15Cv/380Vac/ThreePhase
- 24Vdc deep cycle batteries with electric power pack



ED - HYBRID

- Combustion diesel engine
- 24Vdc deep cycle batteries with electric power pack

STANDARD EQUIPMENTS	VERSION		
	STD	E	ED
Articulated with double telescopic boom	•		
Radio remote control for drive & stab with diagnostic (supplied with emergency wire)	•		
Hydraulically extending under carriage	•		
Double proportional drive speed (slow/fast)	•		
Triple stabilization set-up and automatic monitoring device with no rotation restrictions.	•		
Auto-stabilization by radio remote control.	•		
Automatic recovering push button on-board.	•		
Light allu basket and easily detachable	•		
Spare radio remote control batteries (2 supplied with charger included)	•		
Protected against falling objects by strong metal covers.	•		
Pipes & cables fully protected inside the booms.	•		
Electric outlets available into the basket 230/110Vac	•		
Air 6 water outlets into the basket (high pressure)	•		
Diesel KUBOTA water cooled engine.	•	---	•
Electric-pump 380Vac/3ph/15hp for indoor use	•	•	-
Deep-cycle batteries 24Vdc/420Ah, electric power-pack for indoor use.	---	•	•
Battery charger 24Vdc with power selector.	---	•	•
Phase inverter and electronic alert device.	•	•	---
EXTRAS - ON DEMAND			
STD E ED			
Non-marking tracks for delicate surfaces	•		
Electric emergency descent kit 24Vdc	•	---	---
Wind gauge to monitor max wind speed	•		
Basket working light	•		
Remote diagnostics and fleet-management	•		
Arctic lubricants for low temperature usage	•	---	•
Over-sized nylon plates and recovering frame	•		
Alu detachable basket 1,80x0,80m wide	•		
Alu detachable basket 2,20x0,80m wide	•		
INTERCOM device from basket to ground.	•		
Lithium-ion battery pack for longer working cycle	---	•	•
APPROVALS			
Europe EN280 - Canada: CS-B354 - Australia: AS14.18			



PLATFORM BASKET

PLATFORM BASKET

Via Montessori, 1 - 42028 Poviglio - RE - Italy
Tel. +39 0522 967666 - Fax +39 0522 967667
info@platformbasket.com

